



AiP74HC/HCT08

Quad 2-input And Gate

Product Specification

Specification Revision History:

| Version | Date | Description |
|----------------|-------------|----------------------------------|
| 2012-05-A1 | 2012-05 | New |
| 2023-04-B1 | 2023-04 | Update the template |
| 2026-02-B2 | 2026-02 | Add junction temperature and ESD |
| | | |



Contents

| | |
|--|-----------|
| 1、 General Description..... | 3 |
| 2、 Block Diagram And Pin Description | 6 |
| 2.1、 Block Diagram | 6 |
| 2.2、 Pin Configurations..... | 7 |
| 2.3、 Pin Description | 7 |
| 2.4、 Function Table..... | 7 |
| 3、 Electrical Parameter | 8 |
| 3.1、 Absolute Maximum Ratings..... | 8 |
| 3.2、 Recommended Operating Conditions..... | 8 |
| 3.3、 Electrical Characteristics | 9 |
| 3.3.1、 DC Characteristics 1 | 9 |
| 3.3.2、 DC Characteristics 2 | 10 |
| 3.3.3、 DC Characteristics 3 | 11 |
| 3.3.4、 AC Characteristics 1 | 12 |
| 3.3.5、 AC Characteristics 2 | 13 |
| 3.3.6、 AC Characteristics 3 | 13 |
| 4、 Testing Circuit | 14 |
| 4.1、 AC Testing Circuit | 14 |
| 4.2、 AC Testing Waveforms..... | 14 |
| 4.3、 Measurement Points | 15 |
| 4.4、 Test Data | 15 |
| 5、 Package Information | 16 |
| 5.1、 DIP14 | 16 |
| 5.2、 SOP14 | 17 |
| 5.3、 TSSOP14..... | 18 |
| 6、 Statements And Notes | 19 |
| 6.1、 The name and content of Hazardous substances or Elements in the product | 19 |
| 6.2、 Notes | 19 |



1、 General Description

The AiP74HC/HCT08 is a quad 2-input AND gate. Inputs include clamp diodes. This enables the use of current limiting resistors to interface inputs to voltages in excess of V_{CC} .

Features:

- Input levels:
For AiP74HC08: CMOS level
For AiP74HCT08: TTL level
- Specified from -40°C to $+125^{\circ}\text{C}$
- Packaging information: DIP14/SOP14/TSSOP14

**Ordering Information:****Tube packing specifications:**

| Part number | Packaging form | Marking code | Tube quantity | Boxed tube quantity | Boxed quantity | Notes |
|-------------------|----------------|--------------|----------------|---------------------|------------------|--|
| AiP74HC08DA14.TB | DIP14 | 74HC08 | 25 PCS/tube | 40 tube/box | 1000 PCS/box | Dimensions of plastic enclosure: 19.0mm×6.4mm Pin spacing: 2.54mm |
| AiP74HCT08DA14.TB | DIP14 | 74HCT08 | 25 PCS/tube | 40 tube/box | 1000 PCS/box | Dimensions of plastic enclosure: 19.0mm×6.4mm Pin spacing: 2.54mm |
| AiP74HC08SA14.TB | SOP14 | 74HC08 | 50 PCS/tube | 200 tube/box | 10000 PCS/box | Dimensions of plastic enclosure: 8.7mm×3.9mm Pin spacing: 1.27mm |
| AiP74HCT08SA14.TB | SOP14 | 74HCT08 | 50 PCS/tube | 200 tube/box | 10000 PCS/box | Dimensions of plastic enclosure: 8.7mm×3.9mm Pin spacing: 1.27mm |
| AiP74HC08TA14.TB | TSSOP14 | 74HC08 | 96 PCS/tube | 200 tube/box | 19200 PCS/box | Dimensions of plastic enclosure: 5.0mm×4.4mm Pin spacing: 0.65mm |
| AiP74HCT08TA14.TB | TSSOP14 | 74HCT08 | 96 PCS/tube | 200 tube/box | 19200 PCS/box | Dimensions of plastic enclosure: 5.0mm×4.4mm Pin spacing: 0.65mm |

**Reel packing specifications:**

| Part number | Packaging form | Marking code | Reel quantity | Boxed reel quantity | Notes |
|-------------------|----------------|--------------|------------------|---------------------|---|
| AiP74HC08SA14.TR | SOP14 | 74HC08 | 4000 PCS/reel | 8000 PCS/box | Dimensions of plastic enclosure: 8.7mm×3.9mm Pin spacing: 1.27mm |
| AiP74HCT08SA14.TR | SOP14 | 74HCT08 | 4000 PCS/reel | 8000 PCS/box | Dimensions of plastic enclosure: 8.7mm×3.9mm Pin spacing: 1.27mm |
| AiP74HC08TA14.TR | TSSOP14 | 74HC08 | 5000 PCS/reel | 10000 PCS/box | Dimensions of plastic enclosure: 5.0mm×4.4mm Pin spacing: 0.65mm |
| AiP74HCT08TA14.TR | TSSOP14 | 74HCT08 | 5000 PCS/reel | 10000 PCS/box | Dimensions of plastic enclosure: 5.0mm×4.4mm Pin spacing: 0.65mm |

Note: If the physical information is inconsistent with the ordering information, please refer to the actual product.



2、Block Diagram And Pin Description

2.1、Block Diagram

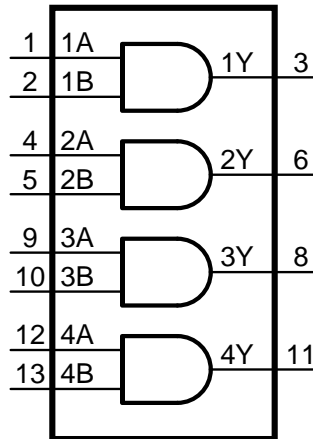

Figure 1. Logic symbol

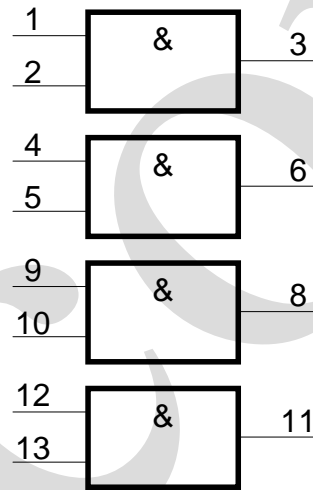

Figure 2. IEC logic symbol

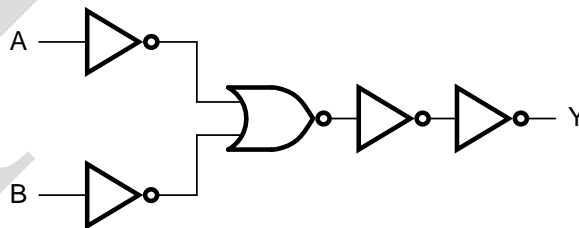
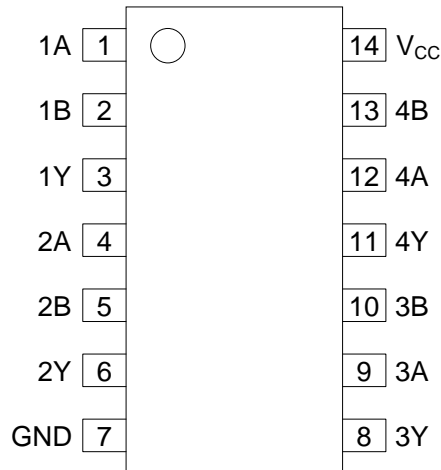

Figure 3. Logic diagram for one gate



2.2、Pin Configurations



2.3、Pin Description

| Pin No. | Pin Name | Description |
|---------|----------|----------------|
| 1 | 1A | data input |
| 2 | 1B | data input |
| 3 | 1Y | data output |
| 4 | 2A | data input |
| 5 | 2B | data input |
| 6 | 2Y | data output |
| 7 | GND | ground (0V) |
| 8 | 3Y | data output |
| 9 | 3A | data input |
| 10 | 3B | data input |
| 11 | 4Y | data output |
| 12 | 4A | data input |
| 13 | 4B | data input |
| 14 | Vcc | supply voltage |

2.4、Function Table

| Input | | Output |
|-------|----|--------|
| nA | nB | nY |
| L | L | L |
| L | H | L |
| H | L | L |
| H | H | H |

Note: H=HIGH voltage level; L=LOW voltage level.



3、Electrical Parameter

3.1、Absolute Maximum Ratings

(Voltages are referenced to GND (ground=0V), unless otherwise specified.)

| Parameter | Symbol | Conditions | Min. | Max. | Unit |
|-------------------------|-----------|--------------------------------------|-----------|----------|-------------|
| supply voltage | V_{CC} | - | -0.5 | +7 | V |
| input clamping current | I_{IK} | $V_I < -0.5V$ or $V_I > V_{CC}+0.5V$ | - | ± 20 | mA |
| output clamping current | I_{OK} | $V_O < -0.5V$ or $V_O > V_{CC}+0.5V$ | - | ± 20 | mA |
| output current | I_O | $-0.5V < V_O < V_{CC}+0.5V$ | - | ± 25 | mA |
| supply current | I_{CC} | - | - | 50 | mA |
| ground current | I_{GND} | - | -50 | - | mA |
| total power dissipation | P_{tot} | - | - | 500 | mW |
| storage temperature | T_{stg} | - | -65 | +150 | $^{\circ}C$ |
| junction temperature | T_J | - | 150 | | $^{\circ}C$ |
| soldering temperature | T_L | 10s | DIP | 245 | $^{\circ}C$ |
| | | | SOP/TSSOP | 260 | $^{\circ}C$ |
| electrostatic discharge | ESD | HBM | 2000 | | V |

3.2、Recommended Operating Conditions

| Parameter | Symbol | Conditions | Min. | Typ. | Max. | Unit |
|-------------------------------------|---------------------|---------------|------|------|----------|-------------|
| AiP74HC08 | | | | | | |
| supply voltage | V_{CC} | - | 2.0 | 5.0 | 6.0 | V |
| input voltage | V_I | - | 0 | - | V_{CC} | V |
| output voltage | V_O | - | 0 | - | V_{CC} | V |
| input transition rise and fall rate | $\Delta t/\Delta V$ | $V_{CC}=2.0V$ | - | - | 625 | ns/V |
| | | $V_{CC}=4.5V$ | - | 1.67 | 139 | ns/V |
| | | $V_{CC}=6.0V$ | - | - | 83 | ns/V |
| ambient temperature | T_{amb} | - | -40 | - | +125 | $^{\circ}C$ |
| AiP74HCT08 | | | | | | |
| supply voltage | V_{CC} | - | 4.5 | 5.0 | 5.5 | V |
| input voltage | V_I | - | 0 | - | V_{CC} | V |
| output voltage | V_O | - | 0 | - | V_{CC} | V |
| input transition rise and fall rate | $\Delta t/\Delta V$ | $V_{CC}=2.0V$ | - | - | - | ns/V |
| | | $V_{CC}=4.5V$ | - | 1.67 | 139 | ns/V |
| | | $V_{CC}=6.0V$ | - | - | - | ns/V |
| ambient temperature | T_{amb} | - | -40 | - | +125 | $^{\circ}C$ |



3.3、Electrical Characteristics

3.3.1、DC Characteristics 1

($T_{amb}=25^{\circ}C$, voltages are referenced to GND (ground=0V), unless otherwise specified.)

| Parameter | Symbol | Conditions | Min. | Typ. | Max. | Unit | |
|---------------------------|-----------------|--|-----------------------------|------|---------|---------|---|
| AiP74HC08 | | | | | | | |
| HIGH-level input voltage | V_{IH} | $V_{CC}=2.0V$ | 1.5 | 1.2 | - | V | |
| | | $V_{CC}=4.5V$ | 3.15 | 2.4 | - | V | |
| | | $V_{CC}=6.0V$ | 4.2 | 3.2 | - | V | |
| LOW-level input voltage | V_{IL} | $V_{CC}=2.0V$ | - | 0.8 | 0.5 | V | |
| | | $V_{CC}=4.5V$ | - | 2.1 | 1.35 | V | |
| | | $V_{CC}=6.0V$ | - | 2.8 | 1.8 | V | |
| HIGH-level output voltage | V_{OH} | $V_I=V_{IH}$ or V_{IL} | $I_O=-20\mu A; V_{CC}=2.0V$ | 1.9 | 2.0 | - | V |
| | | | $I_O=-20\mu A; V_{CC}=4.5V$ | 4.4 | 4.5 | - | V |
| | | | $I_O=-20\mu A; V_{CC}=6.0V$ | 5.9 | 6.0 | - | V |
| | | | $I_O=-4.0mA; V_{CC}=4.5V$ | 3.98 | 4.32 | - | V |
| | | | $I_O=-5.2mA; V_{CC}=6.0V$ | 5.48 | 5.81 | - | V |
| LOW-level output voltage | V_{OL} | $V_I=V_{IH}$ or V_{IL} | $I_O=20\mu A; V_{CC}=2.0V$ | - | 0 | 0.1 | V |
| | | | $I_O=20\mu A; V_{CC}=4.5V$ | - | 0 | 0.1 | V |
| | | | $I_O=20\mu A; V_{CC}=6.0V$ | - | 0 | 0.1 | V |
| | | | $I_O=4.0mA; V_{CC}=4.5V$ | - | 0.15 | 0.26 | V |
| | | | $I_O=5.2mA; V_{CC}=6.0V$ | - | 0.16 | 0.26 | V |
| input leakage current | I_I | $V_I=V_{CC}$ or GND; $V_{CC}=6.0V$ | - | - | ± 1 | μA | |
| supply current | I_{CC} | $V_I=V_{CC}$ or GND; $I_O=0A$; $V_{CC}=6.0V$ | - | - | 2.0 | μA | |
| input capacitance | C_I | - | - | 3.5 | - | pF | |
| AiP74HCT08 | | | | | | | |
| HIGH-level input voltage | V_{IH} | $V_{CC}=4.5V$ to $5.5V$ | 2.0 | 1.6 | - | V | |
| LOW-level input voltage | V_{IL} | $V_{CC}=4.5V$ to $5.5V$ | - | 1.2 | 0.8 | V | |
| HIGH-level output voltage | V_{OH} | $V_I=V_{IH}$ or V_{IL} | $I_O=-20\mu A; V_{CC}=4.5V$ | 4.4 | 4.5 | - | V |
| | | | $I_O=-4.0mA; V_{CC}=4.5V$ | 3.98 | 4.32 | - | V |
| LOW-level output voltage | V_{OL} | $V_I=V_{IH}$ or V_{IL} | $I_O=20\mu A; V_{CC}=4.5V$ | - | 0 | 0.1 | V |
| | | | $I_O=5.2mA; V_{CC}=4.5V$ | - | 0.15 | 0.26 | V |
| input leakage current | I_I | $V_I=V_{CC}$ or GND; $V_{CC}=6.0V$ | - | - | ± 1 | μA | |
| supply current | I_{CC} | $V_I=V_{CC}$ or GND; $I_O=0A$; $V_{CC}=5.5V$ | - | - | 2.0 | μA | |
| additional supply current | ΔI_{CC} | per input pin; $V_I=V_{CC}-2.1V$; $I_O=0A$; other inputs at V_{CC} or GND; $V_{CC}=4.5V$ to $5.5V$ | - | - | 216 | μA | |
| input capacitance | C_I | - | - | 3.5 | - | pF | |



3.3.2、DC Characteristics 2

($T_{amb}=-40^{\circ}\text{C}$ to $+85^{\circ}\text{C}$, voltages are referenced to GND (ground=0V), unless otherwise specified.)

| Parameter | Symbol | Conditions | Min. | Typ. | Max. | Unit | |
|---------------------------|-----------------|--|--|------|---------|---------------|---|
| AiP74HC08 | | | | | | | |
| HIGH-level input voltage | V_{IH} | $V_{CC}=2.0\text{V}$ | 1.5 | - | - | V | |
| | | $V_{CC}=4.5\text{V}$ | 3.15 | - | - | V | |
| | | $V_{CC}=6.0\text{V}$ | 4.2 | - | - | V | |
| LOW-level input voltage | V_{IL} | $V_{CC}=2.0\text{V}$ | - | - | 0.5 | V | |
| | | $V_{CC}=4.5\text{V}$ | - | - | 1.35 | V | |
| | | $V_{CC}=6.0\text{V}$ | - | - | 1.8 | V | |
| HIGH-level output voltage | V_{OH} | $V_I=V_{IH}$ or V_{IL} | $I_O=-20\mu\text{A}; V_{CC}=2.0\text{V}$ | 1.9 | - | - | V |
| | | | $I_O=-20\mu\text{A}; V_{CC}=4.5\text{V}$ | 4.4 | - | - | V |
| | | | $I_O=-20\mu\text{A}; V_{CC}=6.0\text{V}$ | 5.9 | - | - | V |
| | | | $I_O=-4.0\text{mA}; V_{CC}=4.5\text{V}$ | 3.84 | - | - | V |
| | | | $I_O=-5.2\text{mA}; V_{CC}=6.0\text{V}$ | 5.34 | - | - | V |
| LOW-level output voltage | V_{OL} | $V_I=V_{IH}$ or V_{IL} | $I_O=20\mu\text{A}; V_{CC}=2.0\text{V}$ | - | - | 0.1 | V |
| | | | $I_O=20\mu\text{A}; V_{CC}=4.5\text{V}$ | - | - | 0.1 | V |
| | | | $I_O=20\mu\text{A}; V_{CC}=6.0\text{V}$ | - | - | 0.1 | V |
| | | | $I_O=4.0\text{mA}; V_{CC}=4.5\text{V}$ | - | - | 0.33 | V |
| | | | $I_O=5.2\text{mA}; V_{CC}=6.0\text{V}$ | - | - | 0.33 | V |
| input leakage current | I_I | $V_I=V_{CC}$ or GND; $V_{CC}=6.0\text{V}$ | - | - | ± 1 | μA | |
| supply current | I_{CC} | $V_I=V_{CC}$ or GND; $I_O=0\text{A}$; $V_{CC}=6.0\text{V}$ | - | - | 20 | μA | |
| AiP74HCT08 | | | | | | | |
| HIGH-level input voltage | V_{IH} | $V_{CC}=4.5\text{V}$ to 5.5V | 2.0 | - | - | V | |
| LOW-level input voltage | V_{IL} | $V_{CC}=4.5\text{V}$ to 5.5V | - | - | 0.8 | V | |
| HIGH-level output voltage | V_{OH} | $V_I=V_{IH}$ or V_{IL} | $I_O=-20\mu\text{A}; V_{CC}=4.5\text{V}$ | 4.4 | - | - | V |
| | | | $I_O=-4.0\text{mA}; V_{CC}=4.5\text{V}$ | 3.84 | - | - | V |
| LOW-level output voltage | V_{OL} | $V_I=V_{IH}$ or V_{IL} | $I_O=20\mu\text{A}; V_{CC}=4.5\text{V}$ | - | - | 0.1 | V |
| | | | $I_O=5.2\text{mA}; V_{CC}=4.5\text{V}$ | - | - | 0.33 | V |
| input leakage current | I_I | $V_I=V_{CC}$ or GND; $V_{CC}=6.0\text{V}$ | - | - | ± 1 | μA | |
| supply current | I_{CC} | $V_I=V_{CC}$ or GND; $I_O=0\text{A}$; $V_{CC}=5.5\text{V}$ | - | - | 20 | μA | |
| additional supply current | ΔI_{CC} | per input pin; $V_I=V_{CC}-2.1\text{V}$; $I_O=0\text{A}$; other inputs at V_{CC} or GND; $V_{CC}=4.5\text{V}$ to 5.5V | - | - | 270 | μA | |



3.3.3、DC Characteristics 3

($T_{amb}=-40^{\circ}\text{C}$ to $+125^{\circ}\text{C}$, voltages are referenced to GND (ground=0V), unless otherwise specified.)

| Parameter | Symbol | Conditions | Min. | Typ. | Max. | Unit | |
|---------------------------|-----------------|--|--|------|---------|---------------|---|
| AiP74HC08 | | | | | | | |
| HIGH-level input voltage | V_{IH} | $V_{CC}=2.0\text{V}$ | 1.5 | - | - | V | |
| | | $V_{CC}=4.5\text{V}$ | 3.15 | - | - | V | |
| | | $V_{CC}=6.0\text{V}$ | 4.2 | - | - | V | |
| LOW-level input voltage | V_{IL} | $V_{CC}=2.0\text{V}$ | - | - | 0.5 | V | |
| | | $V_{CC}=4.5\text{V}$ | - | - | 1.35 | V | |
| | | $V_{CC}=6.0\text{V}$ | - | - | 1.8 | V | |
| HIGH-level output voltage | V_{OH} | $V_I=V_{IH}$ or V_{IL} | $I_O=-20\mu\text{A}; V_{CC}=2.0\text{V}$ | 1.9 | - | - | V |
| | | | $I_O=-20\mu\text{A}; V_{CC}=4.5\text{V}$ | 4.4 | - | - | V |
| | | | $I_O=-20\mu\text{A}; V_{CC}=6.0\text{V}$ | 5.9 | - | - | V |
| | | | $I_O=-4.0\text{mA}; V_{CC}=4.5\text{V}$ | 3.7 | - | - | V |
| | | | $I_O=-5.2\text{mA}; V_{CC}=6.0\text{V}$ | 5.2 | - | - | V |
| LOW-level output voltage | V_{OL} | $V_I=V_{IH}$ or V_{IL} | $I_O=20\mu\text{A}; V_{CC}=2.0\text{V}$ | - | - | 0.1 | V |
| | | | $I_O=20\mu\text{A}; V_{CC}=4.5\text{V}$ | - | - | 0.1 | V |
| | | | $I_O=20\mu\text{A}; V_{CC}=6.0\text{V}$ | - | - | 0.1 | V |
| | | | $I_O=4.0\text{mA}; V_{CC}=4.5\text{V}$ | - | - | 0.4 | V |
| | | | $I_O=5.2\text{mA}; V_{CC}=6.0\text{V}$ | - | - | 0.4 | V |
| input leakage current | I_I | $V_I=V_{CC}$ or GND; $V_{CC}=6.0\text{V}$ | - | - | ± 1 | μA | |
| supply current | I_{CC} | $V_I=V_{CC}$ or GND; $I_O=0\text{A}$; $V_{CC}=6.0\text{V}$ | - | - | 40 | μA | |
| AiP74HCT08 | | | | | | | |
| HIGH-level input voltage | V_{IH} | $V_{CC}=4.5\text{V}$ to 5.5V | 2.0 | - | - | V | |
| LOW-level input voltage | V_{IL} | $V_{CC}=4.5\text{V}$ to 5.5V | - | - | 0.8 | V | |
| HIGH-level output voltage | V_{OH} | $V_I=V_{IH}$ or V_{IL} | $I_O=-20\mu\text{A}; V_{CC}=4.5\text{V}$ | 4.4 | - | - | V |
| | | | $I_O=-4.0\text{mA}; V_{CC}=4.5\text{V}$ | 3.7 | - | - | V |
| LOW-level output voltage | V_{OL} | $V_I=V_{IH}$ or V_{IL} | $I_O=20\mu\text{A}; V_{CC}=4.5\text{V}$ | - | - | 0.1 | V |
| | | | $I_O=5.2\text{mA}; V_{CC}=4.5\text{V}$ | - | - | 0.4 | V |
| input leakage current | I_I | $V_I=V_{CC}$ or GND; $V_{CC}=6.0\text{V}$ | - | - | ± 1 | μA | |
| supply current | I_{CC} | $V_I=V_{CC}$ or GND; $I_O=0\text{A}$; $V_{CC}=5.5\text{V}$ | - | - | 40 | μA | |
| additional supply current | ΔI_{CC} | per input pin; $V_I=V_{CC}-2.1\text{V}$; $I_O=0\text{A}$; other inputs at V_{CC} or GND; $V_{CC}=4.5\text{V}$ to 5.5V | - | - | 294 | μA | |



3.3.4、AC Characteristics 1

($T_{amb}=25^{\circ}C$, voltages are referenced to GND (ground=0V), unless otherwise specified.)

| Parameter | Symbol | Conditions | Min. | Typ. | Max. | Unit | |
|--------------------------------------|----------|---|------------------------|------|------|------|----|
| AiP74HC08 | | | | | | | |
| nA, nB to nY propagation delay | t_{pd} | see Figure 5 ^[1] | $V_{CC}=2.0V$ | - | 25 | 90 | ns |
| | | | $V_{CC}=4.5V$ | - | 9 | 18 | ns |
| | | | $V_{CC}=5.0V;C_L=15pF$ | - | 7 | - | ns |
| | | | $V_{CC}=6.0V$ | - | 7 | 15 | ns |
| transition time | t_t | see Figure 5 ^[2] | $V_{CC}=2.0V$ | - | 19 | 75 | ns |
| | | | $V_{CC}=4.5V$ | - | 7 | 15 | ns |
| | | | $V_{CC}=6.0V$ | - | 6 | 13 | ns |
| power dissipation capacitance | C_{PD} | per package; $V_I=GND$ to V_{CC} ^[3] | - | 10 | - | pF | |
| AiP74HCT08 | | | | | | | |
| nA, nB to nY propagation delay | t_{pd} | see Figure 5 ^[1] | $V_{CC}=4.5V$ | - | 14 | 24 | ns |
| | | | $V_{CC}=5.0V;C_L=15pF$ | - | 11 | - | ns |
| transition time | t_t | see Figure 5 ^[2] | $V_{CC}=4.5V$ | - | 7 | 15 | ns |
| power dissipation capacitance | C_{PD} | per package; $V_I=GND$ to $V_{CC}-1.5V$ ^[3] | - | 20 | - | pF | |

Note:

[1] t_{pd} is the same as t_{PLH} and t_{PHL} .

[2] t_t is the same as t_{THL} and t_{TLH} .

[3] C_{PD} is used to determine the dynamic power dissipation (P_D in μW).

$$P_D=(C_{PD}\times V_{CC}^2\times f_i\times N)+\sum(C_L\times V_{CC}^2\times f_o) \text{ where:}$$

f_i =input frequency in MHz;

f_o =output frequency in MHz;

C_L =output load capacitance in pF;

V_{CC} =supply voltage in V;

N =number of inputs switching;

$\sum(C_L\times V_{CC}^2\times f_o)$ =sum of outputs.



3.3.5、AC Characteristics 2

($T_{amb}=-40^{\circ}\text{C}$ to $+85^{\circ}\text{C}$, voltages are referenced to GND (ground=0V), unless otherwise specified.)

| Parameter | Symbol | Conditions | Min. | Typ. | Max. | Unit | |
|--------------------------------|----------|-----------------------------|----------------------|------|------|------|----|
| AiP74HC08 | | | | | | | |
| nA, nB to nY propagation delay | t_{pd} | see Figure 5 ^[1] | $V_{CC}=2.0\text{V}$ | - | - | 115 | ns |
| | | | $V_{CC}=4.5\text{V}$ | - | - | 23 | ns |
| | | | $V_{CC}=6.0\text{V}$ | - | - | 20 | ns |
| transition time | t_t | see Figure 5 ^[2] | $V_{CC}=2.0\text{V}$ | - | - | 95 | ns |
| | | | $V_{CC}=4.5\text{V}$ | - | - | 19 | ns |
| | | | $V_{CC}=6.0\text{V}$ | - | - | 16 | ns |
| AiP74HCT08 | | | | | | | |
| nA, nB to nY propagation delay | t_{pd} | see Figure 5 ^[1] | $V_{CC}=4.5\text{V}$ | - | - | 30 | ns |
| transition time | t_t | see Figure 5 ^[2] | $V_{CC}=4.5\text{V}$ | - | - | 19 | ns |

Note:

[1] t_{pd} is the same as t_{PLH} and t_{PHL} .

[2] t_t is the same as t_{THL} and t_{TLH} .

3.3.6、AC Characteristics 3

($T_{amb}=-40^{\circ}\text{C}$ to $+125^{\circ}\text{C}$, voltages are referenced to GND (ground=0V), unless otherwise specified.)

| Parameter | Symbol | Conditions | Min. | Typ. | Max. | Unit | |
|--------------------------------|----------|-----------------------------|----------------------|------|------|------|----|
| AiP74HC08 | | | | | | | |
| nA, nB to nY propagation delay | t_{pd} | see Figure 5 ^[1] | $V_{CC}=2.0\text{V}$ | - | - | 135 | ns |
| | | | $V_{CC}=4.5\text{V}$ | - | - | 27 | ns |
| | | | $V_{CC}=6.0\text{V}$ | - | - | 23 | ns |
| transition time | t_t | see Figure 5 ^[2] | $V_{CC}=2.0\text{V}$ | - | - | 110 | ns |
| | | | $V_{CC}=4.5\text{V}$ | - | - | 22 | ns |
| | | | $V_{CC}=6.0\text{V}$ | - | - | 19 | ns |
| AiP74HCT08 | | | | | | | |
| nA, nB to nY propagation delay | t_{pd} | see Figure 5 ^[1] | $V_{CC}=4.5\text{V}$ | - | - | 36 | ns |
| transition time | t_t | see Figure 5 ^[2] | $V_{CC}=4.5\text{V}$ | - | - | 22 | ns |

Note:

[1] t_{pd} is the same as t_{PLH} and t_{PHL} .

[2] t_t is the same as t_{THL} and t_{TLH} .



4、Testing Circuit

4.1、AC Testing Circuit

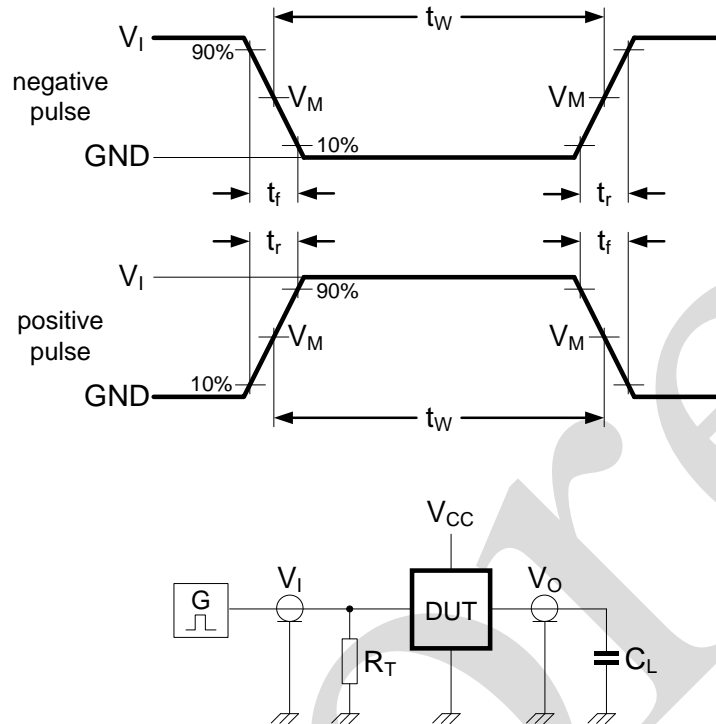

Figure 4. Test circuit for measuring switching times

Definitions for test circuit:

C_L =load capacitance including jig and probe capacitance.

R_T =termination resistance should be equal to the output impedance Z_o of the pulse generator.

4.2、AC Testing Waveforms

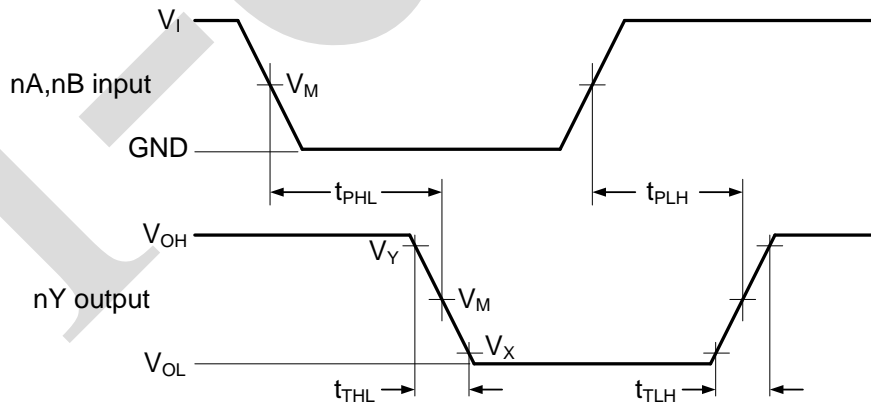

Figure 5. Input to output propagation delays



4.3、Measurement Points

| Type | Input | Output | | |
|------------|---------------------|---------------------|---------------------|---------------------|
| | V_M | V_M | V_X | V_Y |
| AiP74HC08 | $0.5 \times V_{CC}$ | $0.5 \times V_{CC}$ | $0.1 \times V_{CC}$ | $0.9 \times V_{CC}$ |
| AiP74HCT08 | 1.3V | 1.3V | $0.1 \times V_{CC}$ | $0.9 \times V_{CC}$ |

4.4、Test Data

| Type | Input | | Load | Test |
|------------|----------|------------|------------|--------------------|
| | V_I | t_r, t_f | C_L | |
| AiP74HC08 | V_{CC} | 6.0ns | 15pF, 50pF | t_{PLH}, t_{PHL} |
| AiP74HCT08 | 3.0V | 6.0ns | 15pF, 50pF | t_{PLH}, t_{PHL} |



5、Package Information

5.1、DIP14

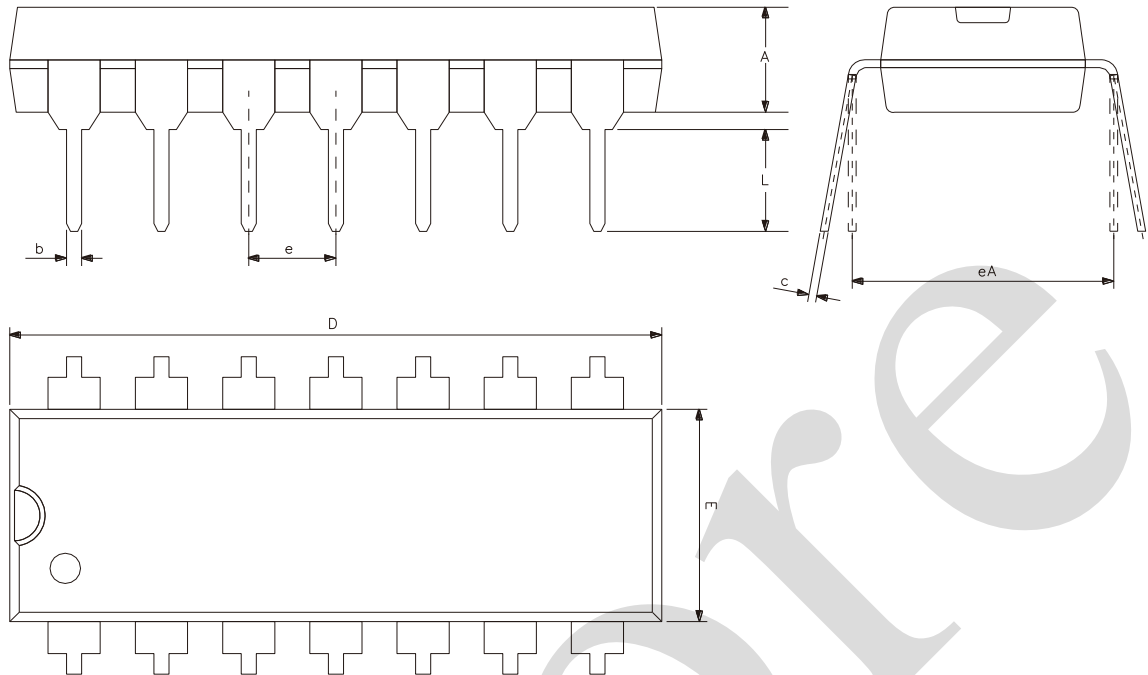

| Symbol | Dimensions (mm) | |
|--------|-----------------|-------|
| | Min. | Max. |
| A | 3.05 | 3.60 |
| b | 0.33 | 0.56 |
| c | 0.20 | 0.36 |
| D | 18.80 | 19.40 |
| E | 6.20 | 6.60 |
| e | 2.54 | |
| eA | 7.62 | 10.90 |
| L | 2.92 | - |



5.2、SOP14

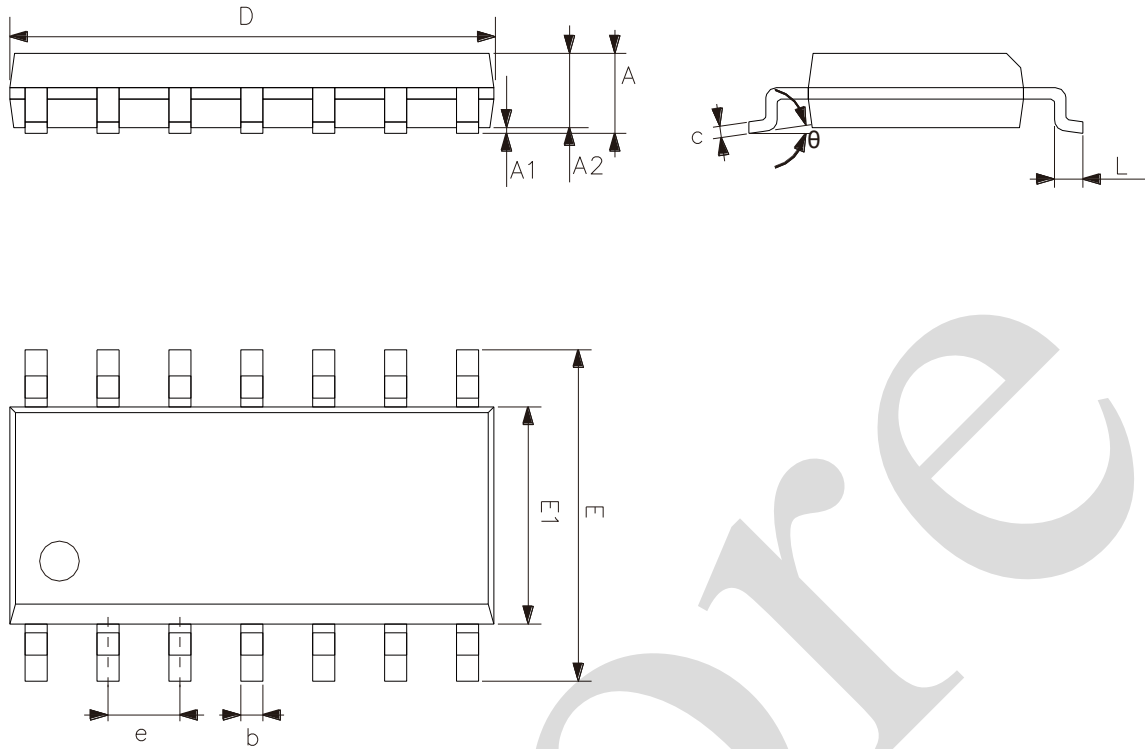

| Symbol | Dimensions (mm) | |
|----------|-----------------|------|
| | Min. | Max. |
| A | 1.50 | 1.75 |
| A1 | 0.05 | 0.25 |
| A2 | 1.30 | - |
| b | 0.33 | 0.50 |
| c | 0.19 | 0.25 |
| D | 8.43 | 8.76 |
| E | 5.80 | 6.25 |
| E1 | 3.75 | 4.00 |
| e | 1.27 | |
| L | 0.40 | 0.89 |
| θ | 0° | 8° |



5.3、TSSOP14

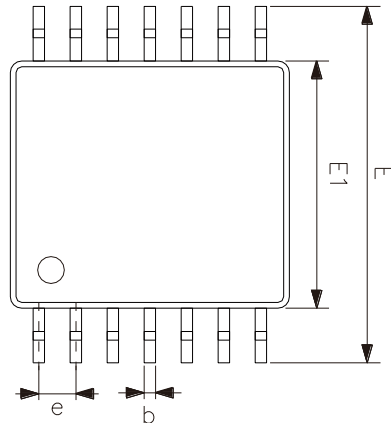
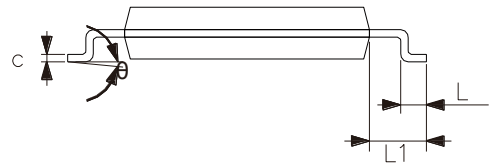
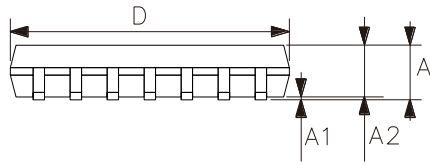

| Symbol | Dimensions (mm) | |
|----------|-----------------|------|
| | Min. | Max. |
| A | - | 1.20 |
| A1 | 0.05 | 0.15 |
| A2 | 0.80 | 1.05 |
| b | 0.19 | 0.30 |
| c | 0.09 | 0.20 |
| D | 4.90 | 5.10 |
| E1 | 4.30 | 4.50 |
| E | 6.20 | 6.60 |
| e | 0.65 | |
| L | 0.45 | 0.75 |
| L1 | 1.00 | |
| θ | 0° | 8° |



6、 Statements And Notes

6.1、 The name and content of Hazardous substances or Elements in the product

| Part name | Hazardous substances or Elements | | | | | | | | | |
|-------------------------|---|-------------------------------|-------------------------------|-------------------------------|--------------------------|--------------------------------|-------------------|-----------------------|---------------------------|----------------------|
| | Lead and lead compounds | Mercury and mercury compounds | Cadmium and cadmium compounds | Hexavalent chromium compounds | Polybrominated biphenyls | Polybrominated biphenyl ethers | Dibutyl phthalate | Butylbenzyl phthalate | Di-2-ethylhexyl phthalate | Diisobutyl phthalate |
| Lead frame | ○ | ○ | ○ | ○ | ○ | ○ | ○ | ○ | ○ | ○ |
| Plastic resin | ○ | ○ | ○ | ○ | ○ | ○ | ○ | ○ | ○ | ○ |
| Chip | ○ | ○ | ○ | ○ | ○ | ○ | ○ | ○ | ○ | ○ |
| The lead | ○ | ○ | ○ | ○ | ○ | ○ | ○ | ○ | ○ | ○ |
| Plastic sheet installed | ○ | ○ | ○ | ○ | ○ | ○ | ○ | ○ | ○ | ○ |
| explanation | ○: Indicates that the content of hazardous substances or elements in the detection limit of the following the SJ/T11363-2006 standard. ×: Indicates that the content of hazardous substances or elements exceeding the SJ/T11363-2006 Standard limit requirements. | | | | | | | | | |

6.2、 Notes

We Recommend you to read this chapter carefully before using this product.

The information in this chapter is provided for reference only and i-Core disclaims any express or implied warranties, including but not limited to applicability, special application or non-infringement of third party rights.

This product is not suitable for critical equipment such as life-saving, life-sustaining or safety equipment. It is also not suitable for applications that may result in personal injury, death, or serious property or environmental damage due to product malfunction or failure. I-Core will not be liable for any damages incurred by the customers at their own risk for such applications.

The customer is responsible for conducting all necessary tests i-Core's application to avoid failure in the application or the application of the customer's third party users. I-Core does not accept any liability.

The Company reserves the right to change or improve the information published in this chapter at any time. The information in this chapter are subject to change without notice. We recommend the customer to consult our sales staff before purchasing.

Please obtain related materials form i-Core's regular channels and we are not responsible for its content if it is provided by sources other than our company.

In case of any conflict between the Chinese and English version, the version is subject to the Chinese one.